

## DC/DC converters TESD10

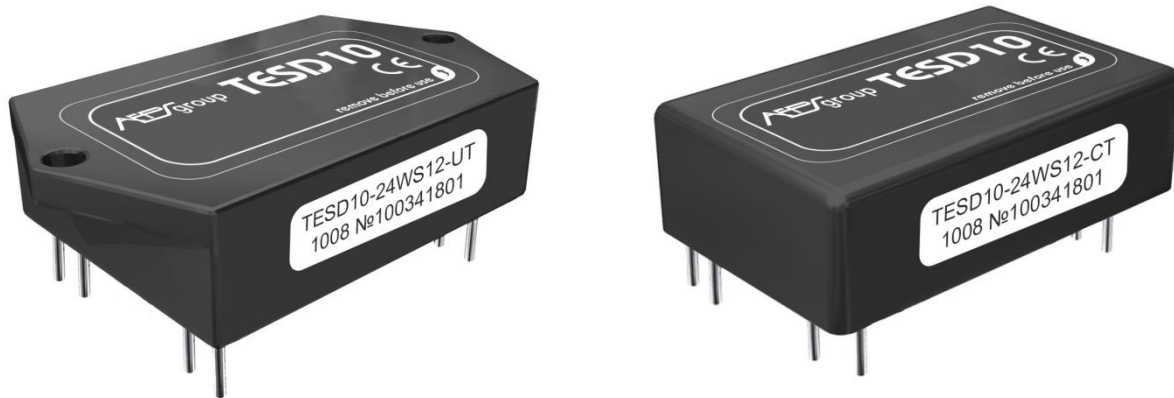

### Features

- Class: Industrial, power density up to **1667 W/dm<sup>3</sup>**
- Low profile 10 mm design
- Working case temperature  $-60^{\circ}\text{C} \dots +110^{\circ}\text{C}$ , for special order – up to  $125^{\circ}\text{C}$
- Output power 10 W; one or two output channels
- Input voltage ranges: 10,5...36 VDC, 18...75 VDC
- Output voltage adjustment, remote on/off
- Max capacitance 800  $\mu\text{F}$  (for  $U_{\text{out}}=5$  VDC, 50% Output power)
- Metal case, with mounting flanges and without flanges

### Description

**Ultra-compact isolated DC/DC converters (modules)** are especially designed for industrial applications and harsh environment operation. These compact units (30 x 20 x 10 mm) have output power up to 10 W and wide operating temperature range between  $-60 \dots +110^{\circ}\text{C}$ , for special order – up to  $125^{\circ}\text{C}$ .

These modules are available with one or two **galvanic isolated** channels, can be switched on/off by a signal, have full protection complex against over current, shorting and overheating and can be connected in parallel or in series.

These modules are built using especially designed electronic components and sealed with heat-conducting potting material. They have wide operating temperature range and thermal protection chip. These modules undergo special thermal and limit tests, including burn-in-tests with extreme on/off modes. They are available in metal cases with mounting flanges.

## Ordering information

### TESD 10 - 24W S 12 - U T

1 2 3 4 5 6 7

- 1 - «TESD» Series
- 2 - Output power, W
- 3 - Input voltages
  - 12W - 12 VDC (10,5...36 VDC)
  - 24W - 24 VDC (18...75 VDC)
- 4 - Index of output channels quantity
  - S - one
  - D - two
- 5 - Nominal output voltage, VDC (two signs for a channel)
- 6 - Index of case design
  - U - metal case with flanges
  - C - metal case without flanges
- 7 - Index of operating temperature range of the case
  - T -60°C...+110°C (standard version), for special order -60°C...+125°C

## Technical information

### Standard models with one output

Module	Input voltage range	Output power	Output voltage / nominal output current	Typical efficiency <sup>1</sup>
TESD10-12WS05-XX	10,5...36 VDC	10 W	5 VDC / 2 A	79%
TESD10-12WS12-XX			12 VDC / 0,83 A	80%
TESD10-12WS15-XX			15 VDC / 0,67 A	81%
TESD10-12WS24-XX			24 VDC / 0,42 A	83%
TESD10-12WS27-XX			27 VDC / 0,37 A	83%
TESD10-12WS48-XX			48 VDC / 0,21 A	84%
TESD10-24WS05-XX	18...75 VDC	10 W	5 VDC / 2 A	80%
TESD10-24WS12-XX			12 VDC / 0,83 A	81%
TESD10-24WS15-XX			15 VDC / 0,67 A	83%
TESD10-24WS24-XX			24 VDC / 0,42 A	84%
TESD10-24WS27-XX			27 VDC / 0,37 A	84%
TESD10-24WS48-XX			48 VDC / 0,21 A	84%

### Standard models with two outputs

Module	Input voltage range	Output power	Output voltage / nominal output current	Typical efficiency <sup>1</sup>
TESD10-12WD0505-XX	10,5...36 VDC	10 W	5 VDC / 1 A ; 5 VDC / 1 A	79%
TESD10-12WD0512-XX			5 VDC / 1 A ; 12 VDC / 0,42 A	80%
TESD10-12WD1212-XX			12 VDC / 0,42 A ; 12 VDC / 0,42 A	81%
TESD10-12WD1515-XX			15 VDC / 0,33 A ; 15 VDC / 0,33 A	83%
TESD10-12WD2727-XX			27 VDC / 0,18 A ; 27 VDC / 0,18 A	83%
TESD10-12WD4848-XX			48 VDC / 0,10 A ; 48 VDC / 0,10 A	84%
TESD10-24WD0505-XX	18...75 VDC	10 W	5 VDC / 1 A ; 5 VDC / 1 A	80%
TESD10-24WD0512-XX			5 VDC / 1 A ; 12 VDC / 0,42 A	81%
TESD10-24WD1212-XX			12 VDC / 0,42 A ; 12 VDC / 0,42 A	83%
TESD10-24WD1515-XX			15 VDC / 0,33 A ; 15 VDC / 0,33 A	84%
TESD10-24WD2727-XX			27 VDC / 0,18 A ; 27 VDC / 0,18 A	84%
TESD10-24WD4848-XX			48 VDC / 0,10 A ; 48 VDC / 0,10 A	84%

Modules with non-standard output voltage from 3 to 60 VDC could be delivered on request.

<sup>1</sup> - Typical efficiency values are given at nominal input voltage under normal climatic conditions

## Specifications for DC/DC converters TESD10\*

<b>Input specifications</b>	
Input voltage range / transitional deviation, 1 sec 12W	=10,5...36 VDC / =10,5...40 VDC
Input voltage range / transitional deviation, 1 sec 24W	=18...75 VDC / =17...84 VDC
Input filter	P-type
<b>Output specifications</b>	
Output voltage adjustment (single-channel models only)	±5% Uout
Instability of output voltage in accordance to changing of output current from 10 to 100% for single output model	±2%
Instability of output voltage in accordance to changing of output current from 30 to 100% for dual output model	±2% out.1, ±12% for chan.2
Instability of output voltage in accordance to changing of input voltage	±0,5%
Ripple and noise (peak-to-peak) (20 MHz)	<2% Uout
Short circuit protection**	>150% Iout nom, auto repair
Overvoltage protection**	<130 % Uout
Over current protection level**	Pout ... 1.3·Pout
Remote On/Off	Shuts down outputs by applying 0...0,5 VDC or connection of output «ON» and «- IN», I≤5mA
Max capacitance for Uout=5 VDC, 50% Output power***	800 µF
<b>General specifications</b>	
Case temperature (operating), index T	-60°C ...+110°C, for order +125°C
Case temperature (storage)	-60°C ...+125°C
High humidity	100% @35 °C
Thermal resistance case — environment without heat sink	19,8 °C/W
Conversion frequency	400-500 kHz
Insulation voltage input/output	=1500 VDC
Insulation voltage input/case	=1500 VDC
Insulation voltage output/case	=1000 VDC
Insulation voltage output/output	=500 VDC
Isolation resistance @ 500 VDC	>20 MOhm
EMC standards	EN 55022, class A; EN 55022, class B with additional filter
Safety standards	IEC/ EN 60950
Typical MTBF (Tcase = 50°C; Pout = 0,7 Pout max)	200 000 hrs
Cooling metod	Free air convection or forced air cooling
Weight (max)	22 g

\* All specifications are valid for normal climatic conditions, Uin.nom., Iout.nom., unless otherwise stated.

\*\* Parameters are stated for the information purposes and could not be used at long term work, exciding maximum output current, at work outside of a range of operating temperatures.

\*\*\* For other output voltages the maximum output capacity is calculated from the fact that  $C_{max} \times U_{out}^2$  is a constant.

### Maximum output power vs ambient temperature

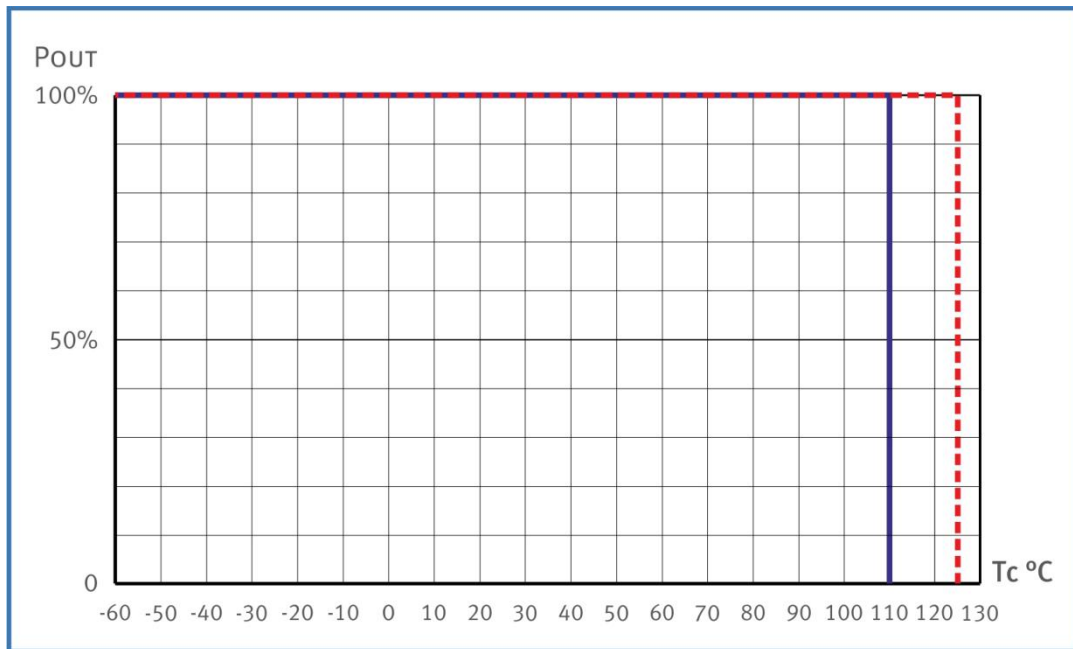

— Allowed power output and case temperature range for standard version of unit.

- - - Possible range of output power and case temperature up to 125°C for special order.

For modeling optimal heatsink and its delivery, with goal of providing allowed case temperatures, please contact us directly [aeps@aeps-group.cz](mailto:aeps@aeps-group.cz)

## Pin out

N° Pin	2,3	4	9	11	14	15	16	22,23	24
Single output	- IN	ON	NOT USE	NOT USE	+OUT	ADJ	-OUT	+IN	CASE
Dual output	- IN	ON	+OUT2	-OUT2	+OUT1	-	-OUT1	+IN	CASE

### Single output model with flanges (I case type)

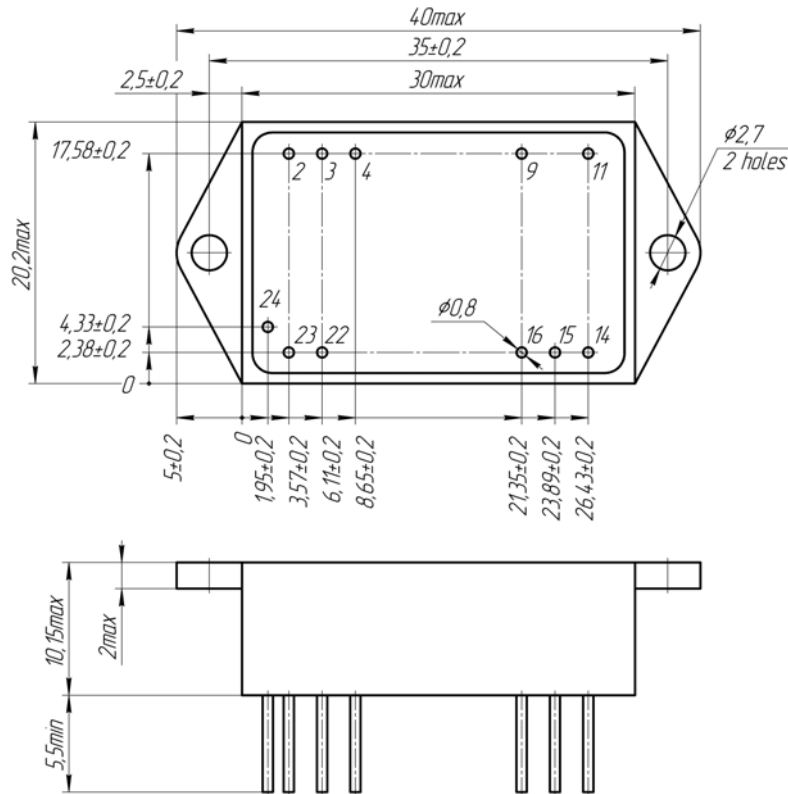

### Single output model without flanges (I case type)

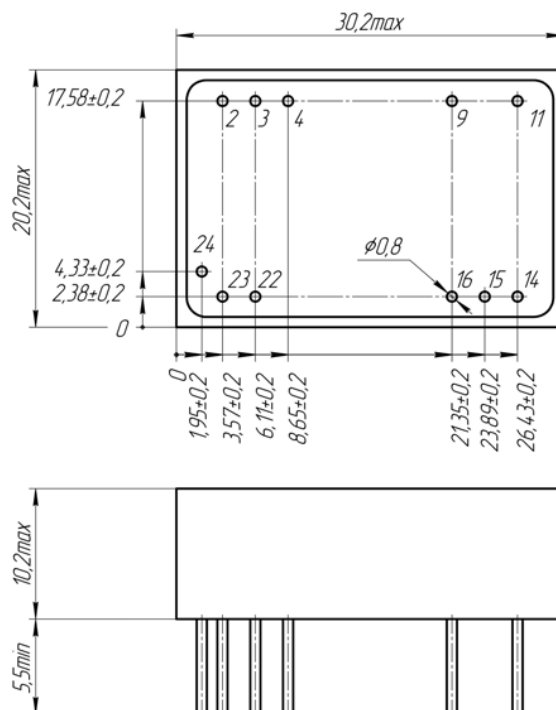

**Dual output model with flanges (I case type)**

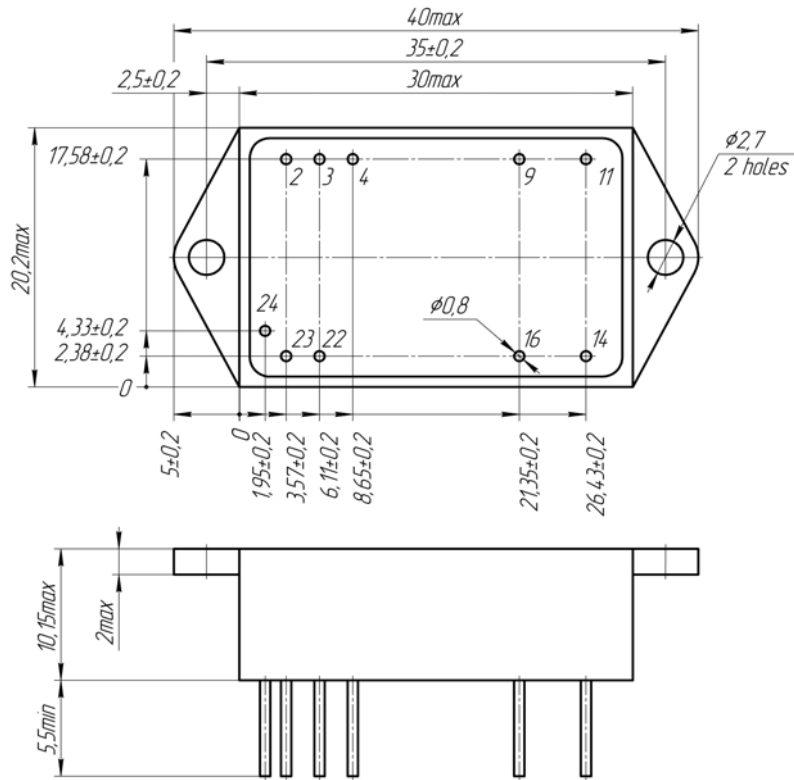

**Dual output model without flanges (I case type)**

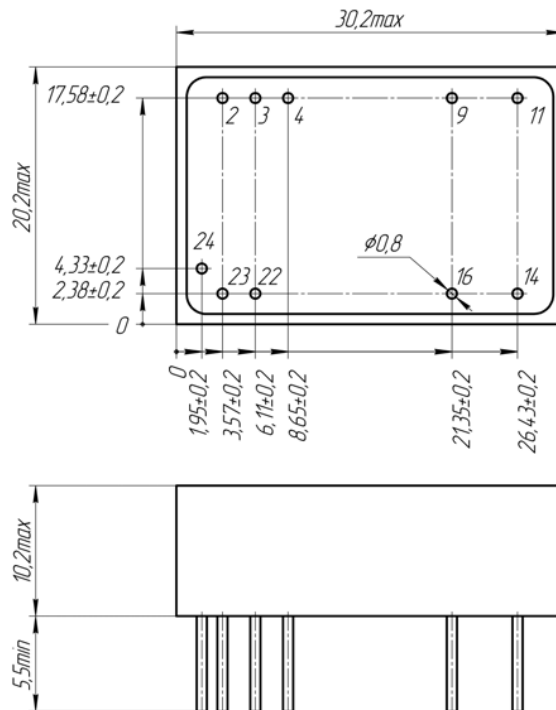

## Certificates

Certificate ISO 9001\*  
CE conformity declaration

\* Management system and R&D of Alexander Electric is ISO certified

## Note

The label with sign "remove before use" can be placed on the top surface of the module and must be removed before installation.

Please, note that all information in this material is for reference only. Further detailed information (including: additional requirements, manuals and circuit schemes) is found on our website <http://www.teslaelectric-eu.com>.

## Contact information

<http://www.teslaelectric-eu.com>, e-mail: [aeps@aeps-group.cz](mailto:aeps@aeps-group.cz), phone/fax: +420 281 001 341

According to company's policy in view of constant improvements of the production design the manufacturer reserves the right to itself change the contents of promotional materials without prior notification.